



WHITE LITE INDUSTRIES PTY. LTD.

A.C.N. 000 123 508

Unit 5-7/42 Beaumont Rd, Mt. Kuring-gai, NSW 2080, Australia

P.O. Box 47, Mt. Kuring-gai, NSW 2080, Australia

Telephone: (02) 9457 8877 Fax: (02) 9457 9596

Email: info@white-lite.com.au

Home Page: www.white-lite.com.au

C.A.T.S. II



COMPUTERISED AUTOMATIC TESTING SYSTEM

<i>PART 1</i>	Design & Specification	Page 2
<i>PART 2</i>	Installation Instructions	Page 14
<i>PART 3</i>	Trouble Shooting	Page 20

PART I
DESIGN & SPECIFICATION

Section One:

White Lite Industries, an Australian owned progressive emergency lighting company had a modest start some 50 years ago. White Lite is now one of Australia's leading designers & manufacturers of EXIT & Emergency lighting and enjoys a solid reputation for innovation & quality. White Lite Industries would now like to present the **CATSII** Design section, which includes all related issues with regard to Project Design.

CATSII adopts a reliable industry standard proven communications protocol to monitor & test upto 16,000 emergency luminaires, wired through an easily installed tree-branch or daisy-chain cable network to suit many building types.

Initially launched in 1992 has been well accepted by Consulting Engineers and End-users alike, with numerous successful installations in many different builing types, over the Oceanic region. These may include: Hospitals (Orange Base Hospital, Orange; Sydney Adventist Hospital, Wahroonga; Royal North Shore Hospital, St Leonards), Office Towers (NCR House, North Sydney; Centrepont Tower, Sydney), Airports (Wellington International Airport, Wellington & Christchurch International Airport, Christchurch [NZ]), University Campuses (Newcastle University, Newcastle; Christchurch University, Christchurch, [NZ]) and Shopping Centres (Broadway Shopping Centre, Sydney; Chadstone Shopping Centre, Chadstone, Victoria). (For a more complete listing, go to the end of this section)

CATSII includes several unique features, which when combined will provide a simple system for monitoring all emergency lighting applications. The features are as follows:

- Unique "*at a glance*" Status screen shows the operational status of up to 1,300 luminaires per page (scans 4,000 **CATSII** luminaires per minute).
- Simple to install, wire & commission with either a tree-branch multi-drop or a daisy-chain cabling layout to suit individual building layouts.

(see below)

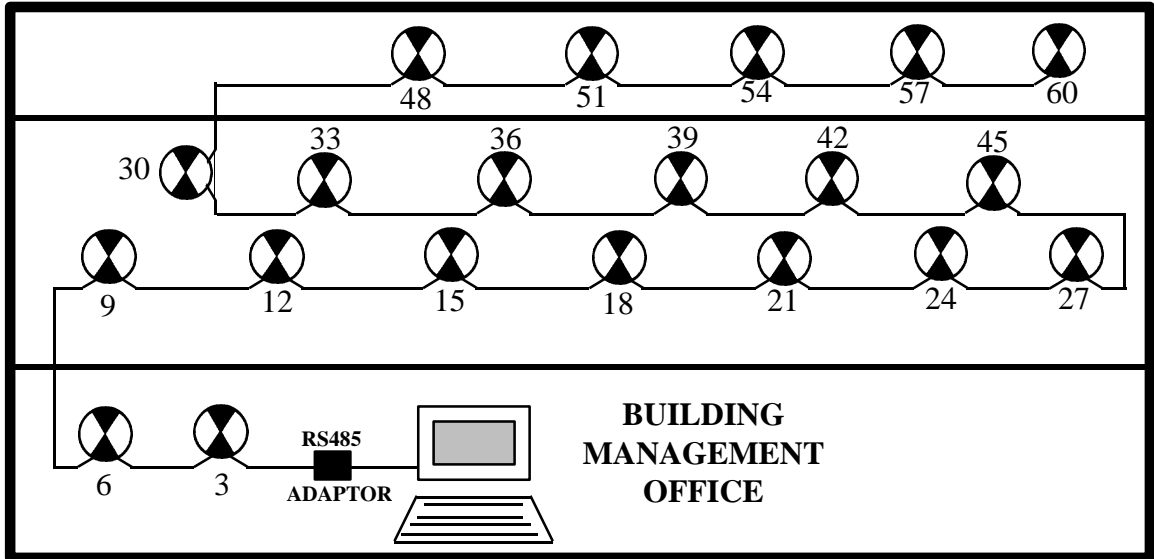

Figure 1a: Daisy-chain data cable design layout.

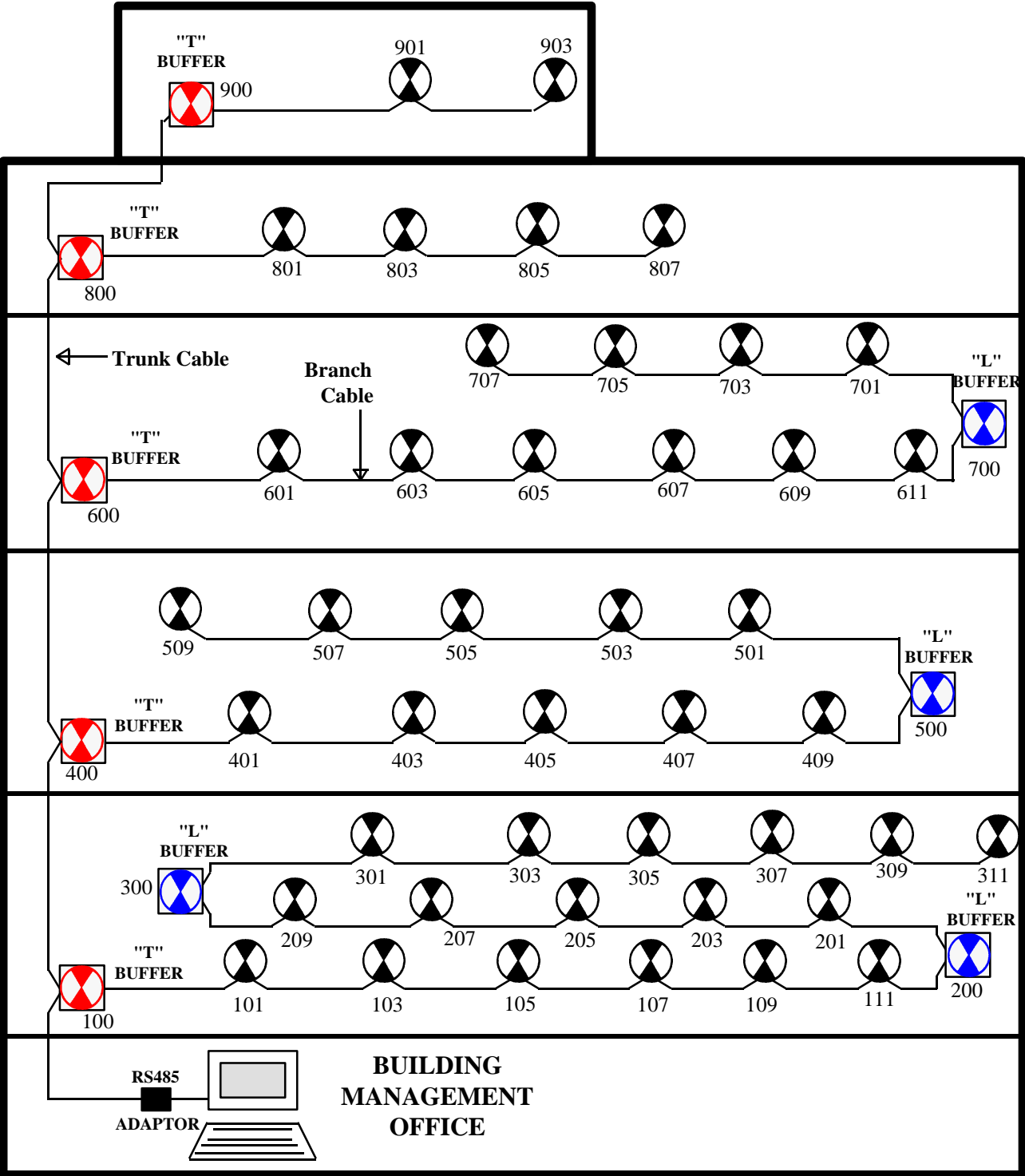

Figure 1b: Tree-Branch Multi-drop data cable design layout.

- Easy-to-use "windows" style operating software including full HELP menu.
- Easy to add, relocate, remove and/or replace a **CATSII** luminaire with renumbering easily carried out on site.

- Simple print-out reports commands for key reports & "units requiring attention".
- Large sites can be interconnected over Ethernet LAN networks and monitored from a single location. Dial-up modem access also available.

All **CATSII** installations are capable monitoring up to 16,000 emergency luminaires at any one time. The "at a glance Status screen" allows the controller to view upto 1,300 luminaires per screen, as well as scanning 4,000 luminaires per minute. The system allows the operator to view any tests being performed via a TEST STATUS screen, ensuring that no luminaire has been forgotten. Test times, days, frequency and test duration can be easily modified, so that they can occur with a remote PC or without the PC being connected. The program provides a "Test Abort" facility, which will stop all tests at any time.

Test results can be quickly displayed with clear coloured symbols/letters indicating the cause of failure. All **CATSII** units utilise a bi-colour LED, for quick location, indicating whether the units are operating correctly or which units require immediate attention.

The system produces easy to follow "Fault Test" reports for the system operator. Included in these reports are information on the Location, Type, Fault description and key spare parts necessary with the associated catalogue numbers.

Section 2

The design shall comprise of a network of emergency luminaires and exit signs to be monitored and tested by a computerised system using the White Lite Industries "**CATSII**" software.

White Lite Industries suggests that the design includes the following components;

- comprehensive site or building layouts.
(eg: architectural or drafting plans)
- on-site computer.
- site cabling layout.
- preliminary list of emergency luminaires and exits.
- a recent list of mutual interests involved.
(eg: consultants,wholesalers, contractors, etc)

The computer must be a minimum of 486SX 40MB hard disk, 4MB RAM, 3½" floppy disk drive, MS-DOS 6.22, plus the necessary computer accessories. The computer must be have a dedicated communication serial port for the RS232-485 converter. **Please note that the maximum computer operating system applicable is Windows NT (V.3+ S.P.: 4 - 6). CATSII software will not operate on Windows 2000 or WindowsXP**

The cable type will include any DATA/Communication Cable with 240V rating. The cable shall be of shielded twisted pair, 7/0.2 mm multistrand data cable. The cable will feed directly into the computer RS485 adaptor, to run in parallel to each luminaire. The cable shall terminate with the last emergency luminaire on site. It is not necessary to loop back to the computer.

The data cable must be kept segregated from the mains (low & high voltage) cables at all times.

Recommended distance must be of at least 300mm. To prevent and protect cables from damage, must have wire protectors covering any terminal blocks or connection points.

We understand the problems associated with designing a lighting installation in a building and as a result, White Lite Industries recommends that those involved in the planning and design stages use the following steps laid out below:

Step 1: System Specification

The system shall:

- have a "system screen" which shall indicate the current status of up to a total of 1300 luminaires on each screen. Each screen shall indicate, when detected, the following luminaire conditions;

- ◆ luminaire healthy - no faults
- ◆ low tube lux level
- ◆ low battery voltage
- ◆ excessive battery voltage drop during discharge
- ◆ luminaire unable to communicate
- ◆ microprocessor memory failure
- ◆ luminaire not connected
- ◆ new unit not logged on
- ◆ break in communications cable
- ◆ mains lamp fault indicated within 2 minutes of failure

- have a manual & sequential numbering system, controlled by the installing contractor, so that in each group of luminaires spare places are left for any future additions to the system which will not effect the numbering and geographical location of any luminaire.

- be able to print fault reports showing the faulty part and its catalogue number.

- be so configured that each luminaire is able to automatically test and store the results in its own memory for later retrieval. Each luminaire shall have the capacity to store in memory, up to five (5) recent test reports for assessment, complete with optional logging and/or printing.

- be designed to enable each luminaire to continue to automatically test itself in the event of a communication line failure, computer failure or interface failure.

- be run via RS485 communication data cable with no return loop of the cable back to the computer required.

- continue to operate and run automatic tests after the computer or interface has been disconnected from the communication cable.

• have the facility to run either "quick" or "full" tests whenever required by maintenance personnel, both automatically and manually.

• have a history facility to log luminaire test reports onto hard disk storage on commissioning (or anytime) for comparison with future luminaire test reports.

• during and after tests have an on screen message "----- test in progress" and "test completed".

The below Exit Signs and Emergency luminaires are only a *sample* of the White Lite products that can be fitted with CATS II. Also available with CATS II is the 110V DC and the Millenium range. Please call your local state office for more information. Please call White Lite direct or contact our state agents and distributors for further information. (See page #)

1. EXIT SIGNS

See key below for diffuser specifications and add appropriate number to White Lite catalogue number, e.g. SIL110/6 if requiring a ceiling mounted, single sided SILHOUETTE Exit Sign with arrow pointing left.

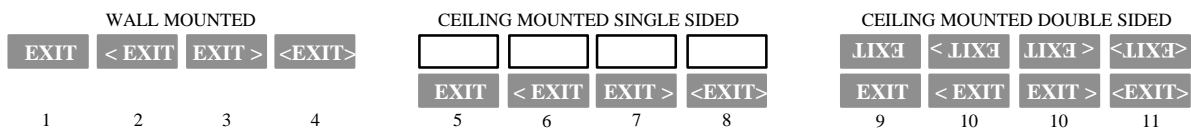

<u>Catalogue No.</u>	<u>Description</u>	<u>C0.</u>	<u>C90.</u>
SILHOUETTE - 10W "Quick Fix" style Exit			
SILC110/(1-11)	1x10W Maintained	-	-
SILC210/(1-11)	2x10W Sustained	-	-
SILC110DL/(1-11)	1x10W Maintained with DOWN LIGHT Option	C6.3	C5
SILC210DL/(1-11)	2x10W Sustained with DOWN LIGHT Option	C6.3	C5
EDGE LIGHT II - 10W "Edge Light" style Exit			
ELC110F/(5-8)	1x10W Maintained Recessed Single Sided	C6.3	C5
ELC110F/(9-11)	1x10W Maintained Recessed Double Sided	B5	C6.3
MUSTANG - 10W "Universal" style Exit			
MGC110M/(1-4)	1x10W Maintained Wall Mounted	C6.3	E8
MGC110M/(5-11)	1x10W Maintained Ceiling Mounted	C6.3	E6.3
MGC210S/(1-4)	2x10W Sustained Wall Mounted	C6.3	E8
MGC210S/(5-11)	2x10W Sustained Ceiling Mounted	C6.3	E6.3
MILLENIUM SERIES :			
SPECTRO Exit Sign			
WL2003/(5-11)	1x8W Maintained Single/Double Wall mtd	E2.5	E8
WL2033/(5-11)	1x8W Maintained Single/Double Ceiling Mtd	E2.5	E8
WL2063/(5-11)	1x8W Maintained Single/Double Integral	E2.5	E8
ELIPS Exit Sign			
WL2103/(5-11)	1x8W Maintained Single/Double Surface Mtd	D3.2	E8
WL2133/(5-11)	1x8W Maintained Single/Double Recessed Mtd	D3.2	E8
OPTEK Exit Sign			
WL2163/(1-4)	1x8W Maintained Single Sided Wall Mtd	E1	E0.63
WL2173/(5-11)	1x8W Maintained Double Sided Ceiling Mtd	D1.6	E1

WEATHERPROOF - 10W IP67 Rated Weatherproof Exit

CPC110CR/(1-8)	1x10W Maintained Single Sided only	-	-
CPC210CR/(1-8)	2x10W Sustained Single Sided only	-	-

WEATHERPROOF - 10W IP65 Rated Weatherproof Exit

WPC110/1-11	1x10W Maintained Surface mount	E2.5	E2
WPC010/Opal	1x10W Maintained Surface mount Opal Diffuser	E4	E3.2

2. EMERGENCY LUMINAIRES

PATHFINDER - 10W 6V Halogen Recessed Emergency Luminaire

PFC10F	10W Non-Maintained Nicad Recessed (120mm diameter)	D20	D20
PFMC10F	10W Non-Maintained Nicad Recessed (75mm diameter)	D20	D20
PFSQC10	10W Non-Maintained Nicad Surface Mount	D20	D20
PFC10LF	10W Non-Maintained Lead Acid Recessed (120 mm ")	D25	D25

BARE AND WIREGUARDED BATTENS

BEC118NM	1x18W Non-Maintained	D20	E20
BEC118WGNM	1x18W Non-Maintained Wireguarded	D20	E20
BEC118M	1x18W Maintained	D20	E20
BEC118WGM	1x18W Maintained Wireguarded	D20	E20
BEC218M	2x18W Combined Maintained	D20	E20
BEC218WGM	2x18W Combined Maintained Wireguarded	D20	E6.3
BEC136NM	1x36W Non-Maintained	D40	C40
BEC136WGNM	1x36W Non-Maintained Wireguarded	D40	C40
BEC136M	1x36W Maintained	D40	C40
BEC136WGM	1x36W Maintained Wireguarded	D40	C40
BEC236M	2x36W Combined Maintained	D63	D20
BEC236WGM	2x36W Combined Maintained Wireguarded	D40	C50

PRISMATIC DIFFUSED BATTENS

SSC118NM	1x18W Non-Maintained	D25	E16
SSC118M	1x18W Maintained	D25	E16
SSC218M	2x18W Combined Maintained	E25	E16
SSC136NM	1x36W Non-Maintained	D40	C25
SSC136M	1x36W Maintained	D40	C25
SSC236M	2x36W Combined Maintained	D63	C50

WEATHERPROOF BATTENS IP65 RATING

CPC118NM	1x18W Non-Maintained	-	-
CPC118M	1x18W Maintained	-	-
CPC218M	2x18W Combined Maintained	-	-
CPC136NM	1x36W Non-Maintained	-	-
CPC136M	1x36W Maintained	-	-
CPC236M	2x36W Combined Maintained	D50	C32

Step 2: Provision from and for Site

- comprehensive site and building layouts.
(eg: architectural or drafting plans)
- preliminary list of emergency luminaires and exits.
- personal Computer (PC) loaded with **CATSII software**.
- copies of the Australian Standards and Building Code of Australia with reference to Emergency Lighting, Exit Signs and Warning Systems.

Step 3: Completed details about system on Site

On the plans or drawings you will need to label them with the following items;

- location of emergency exits and luminaires.
- the layout of the data cable, joining each fitting to be connected to the **CATSII** system, c/w luminaire CATS numbers for each unit to be connected to the data cable
- PC location on site.

(Suggestion: For easier luminaire identification use different colours or symbols for the different luminaire types, on the plans.)

A complete set of the marked up plans must be sent to White Lite to them for approval. See the below figure as an example of this.

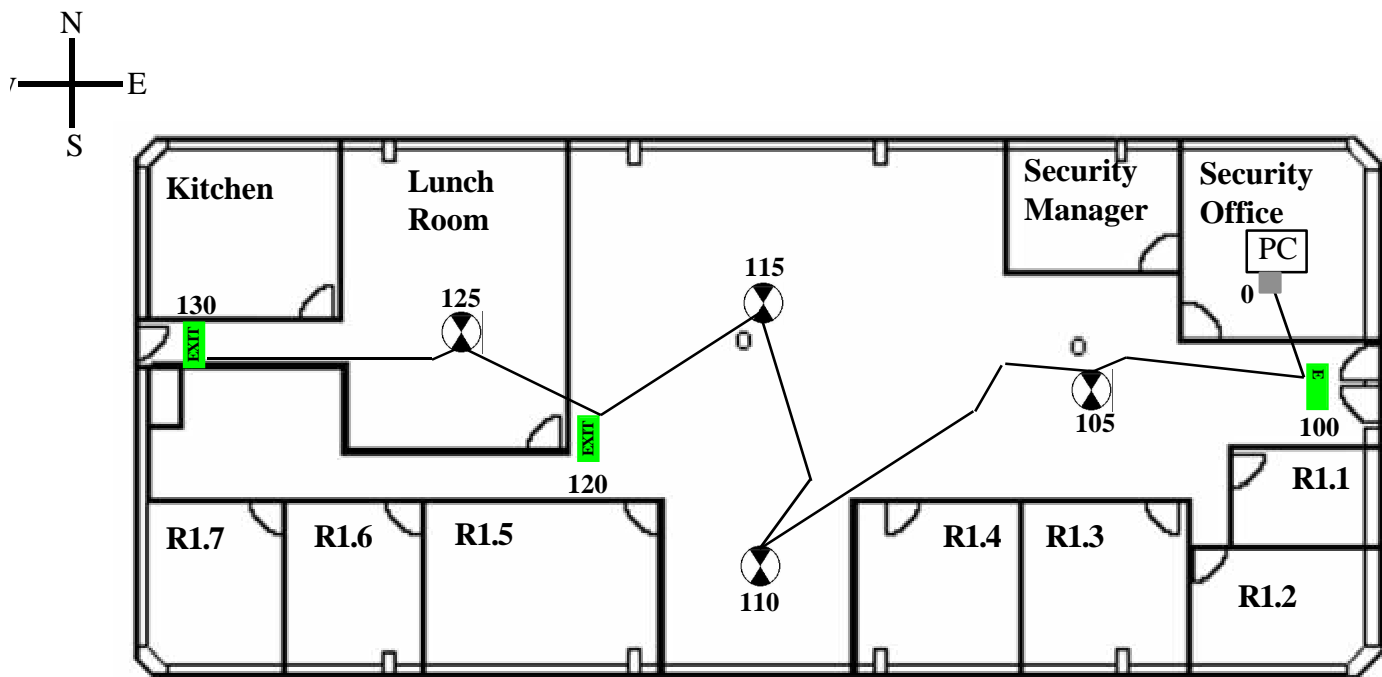

As well as site drawings and cable layout, there is a third procedure required for the system. The CATSII software is capable of holding the location of each luminaire connected to the system. Location details are not only important to those who are commissioning the site, but these details will assist the maintenance people. These details can include installed location, which distribution board or circuit number, CATSII address number and luminaire type. An example of the layout has been provided on page 9. This layout is required from the project designer or electrical contractor, to be given to White Lite's project managers.

CATS II PROJECTS

PROJECT NAME	Yr Completed	ON GOING
NEW SOUTH WALES		
FACTORY COMPLEX - SMITHFIELD	1992	
UNIVERSITY OF NSW: FIG TREE THEATRE - SYDNEY	1992	
NSW LANDS DEPARTMENT BUILDING - SYDNEY	1993	
HONEYWELL HEAD OFFICE - NORTH RYDE	1993	
SANITARIUM ADVENTIST HOSPITAL - WAHROONGA	1996	
HIGHGATE APARTMENTS - SYDNEY	1996	
CATHAY PACIFIC HEAD OFFICE - CASTLE HILL	1994	
10 BRIDGE STREET - SYDNEY	1997	
AUSTRALIA POST - COFFS HARBOUR	1994	
PRECISION VALVES COMPNAY	1993	
READERS DIGEST HEAD OFFICE - SYDNEY	1995	
AUTUMN LODGE - COFFS HARBOUR	1994	
COFFS HARBOUR TAVERN COMPLEX	1994	
MASTERFOODS/TOP HAT - MT KURING-GAI	1997	
UNIVERSITY OF NEWCASTLE		X
HUNTER BLDG	1996	
GEOLOGY BLDG	1998	
MCMULLIN BLDG	1997	
BEHAVIOURAL BLDG	1998	
NURSING FACULTY BLDG	1997	
AUCHMUTY LIBRARY	1997	
MAINTENANCE DEPARTMENT	1997	
AVIATION BLDG	1998	
LINK BLDG	1999	
UNIVERSITY LODGE	2000	
ENGINEERING BLDGS D, E & F	2001	
ABSTI CENTRE		X
SOCIAL SCIENCES BLDG		X
UNIVERSITY CARPARK	2001	
STUDENT ACCOMODATION	1999	
OSNAM VILLA UNITS - COFFS HARBOUR	1996	
PARK BEACH PLAZA - COFFS HARBOUR	1996	
C.S.I.R.O. - NORTH RYDE	1996	
ORANGE BASE HOSPITAL - ORANGE	1996	
GRACE BROS BROADWAY REDEVELOPMENT - SYDNEY	1997	
ROYAL AGRICULTURE SHOWGROUND - HOMEBUSH	1997	
PIGS, ALPACAS & CATTLE BLDG B & C		
HORSES PAVILIONS BLDGS H, I, K & L		
BLDG P		
CLYDESDALE PAVILION BLDG N		
HORSES MARSHALLING ARENA		
PONY PAVILION BLDG G & M		
CATTLE PAVILIONS BLDGS E & F		
STATE INDOOR SPORTS CENTRE - HOMEBUSH	1996	
QUEEN VICTORIA BUILDING SHOPPING CENTRE	1999	
NCR HOUSE - NORTH SYDNEY	1997	
CUSTOMS HOUSE - CIRCULAR QUAY	1997	

PROJECT NAME	Yr Completed	ON GOING
ROYAL NORTH SHORE HOSPITAL		X
STURT HOUSE	2001	
UTS CAMPUS - HAYMARKET	1995	
BATHURST BASE HOSPITAL	1997	
HENRY DEANE PARK - CENTRAL RAILWAY	2000	
PIHANA PACIFIC INTERNET EXCHANGE - MASCOT	2001	
ELAROSA/HORIZONS APARTMENTS - DARLINGHURST	1998	
FORUM WEST APARTMENTS - ST LEONARDS	2001	
NSW SHOOTING CENTRE - ELIZABETH PARK	1999	
SYDNEY CENTREPOINT TOWER	2001	
ART GALLERY OF NSW - SYDNEY	2001	
STANDARDS AUSTRALIA HEADQUARTERS - SYDNEY		X
MITCHELL LIBRARY AT NSW LIBRARY - SYDNEY	2001	
DUNC GREY VELODROME - BASS HILL	1999	
BARINGA PRIVATE HOSPITAL	1997	
PORT WARATAH DEVELOPMENT - NEWCASTLE	1997	
NAMBUCCA NURSING HOME	1995	
GLOBAL SWITCH INTERNET EXCHANGE	2001	
CONCORDIA CLUB - STANMORE	2000	
PETTINGER/HUNTER HEALTH BLDG - NEWCASTLE	2001	
GREATER BUILDING SOCIETY - NEWCASTLE	2001	
AUSTRALIAN CAPITAL TERRITORY		
AUSTRALIAN GEOGRAPHIC SURVEY ORGANISATION	1996	
VICTORIA		
SOLDIERS, SAILORS & AIRMEN CLUB - ALBURY	1997	
CHADSTONE SHOPPING CENTRE	1998	
150 LONSDALE STREET - MELBOURNE	1997	
DANDENONG KINDERGARTEN	1996	
FLINT INKS	2001	
KILLARA HOSTEL - MELBOURNE	1998	
SOUTH AUSTRALIA		
STATE ADMIN CONSERVATION BLDG - ADELAIDE	1993	
FLINDERS PRIVATE HOSPITAL	1997	
HOLDFAST SHORES	1998	
WESTERN AUSTRALIA		
PARLIAMENT OF WA	2001	
QUEENSLAND		
CATHEDRAL PLACE	1998	
DAVID JONES DEPARTMENT COMPLEX - ROBINA	1996	
EARLSVILLE SHOPPING CENTRE	1994	
PEANUT FACTORY - KINGAROY	2001	
ROMA GOVERNMENT OFFICES	2000	
DOOMDEN RACETRACK	2000	
XXXX BREWERY - BAWRIN	1999	
PAUL'S ICE CREAMERY FACTORY		X

WHITE LITE INDUSTRIES

PROJECT NAME	Yr Completed	ON GOING
TASMANIA		
TRUST BANK - HOBART	1998	
TREVALLYN POWER STATION - LAUNCESTON	1998	
SIMPLOT AUSTRALIA - ULVERSTON	1996	
GLENORCHY CITY COUNCIL CHAMBERS	1998	
NORTHERN COMMUNICATIONS CENTRE - LAUNCESTON	1998	
MCCAIN'S FROZEN FOODS - SMITHTON	1998	
HYDRO ELECTRIC COMMISSION BLDG - MOONAH	1996	
BERRIDALE CHILD CARE CENTRE	1997	
MARINE BOARD - HOBART	1997	
BBC HARDWARE CENTRE	1998	
RIVERSIDE PRIMARY SCHOOL	1997	
CALVARY HOSPITAL - HOBART	1998	
I.E.M.C. BLDG - MOONAH	1997	
CLYDESDALE CHILD CARE CENTRE	1997	
VODAPHONE CALL CENTRE - KINGSTONE	2000	
GLENORCHY COUNCIL WORKS DEPOT	1999	
GLENORCHY PICTURE THEATRE COMPLEX	1999	
AMINYA NURSING HOME	1999	
KIRKSWAY HOUSE	2000	
MAWSON PLACE - HOBART WHARF	2000	
SCOTTSDALE MEMORIAL HOSPITAL	1998	
SIMPLOT DAVENPORT	1999	
BENJAFIELD CHILD CARE	2000	
DERWENT PARK CHILD CARE CENTRE	1999	
ELDERCARE NURSING HOME		X
BMW SHOWROOM - HOBART		X
MARKET PLACE CARPARK		X
HOBART WOOLSTORE APARTMENTS		X
ST JOHNS HOSPITAL		X
NEW ZEALAND		
CANTEBURY UNIVERSITY - CHRISTCHURCH		
PYSCOLOGY BLDG	1998	
COMMERCE BLDG	1996	
PHYSICS BLDG	1996	
CIVIL-MECHANICAL BLDG	1996	
SOUTH ARTS LECTURE THEATRE	1997	
FORESTRY BLDG	1997	
STUDENT UNION BLDG	1997	
JAMES HIGHT BLDG	1998	
MATHS BLDG	1997	
PACIFIC STUDIES BLDG	1997	
MOARI STUDIES BLDG	1997	
HALLS OF RESIDENCE	1997	
CIVIC BLOCK B	1996	
DELLOITE HOUSE - AUCKLAND	1998	
MASSEY COMMUNITY CENTRE	1998	
WELLINGTON INTERNATIONAL AIRPORT	2000	
CHRISTCHURCH INTERNATIONAL AIRPORT	1997	
RESERVE BANK - WELLINGTON	1999	

CATSII SELF DIAGNOSTIC SYSTEM (SDS) EMERGENCY LUMINAIRES



White Lite is an Australian owned progressive emergency lighting manufacturer, which in keeping with its tradition of providing innovative products to the market has developed a new option for its emergency lighting monitoring system.

To correspond with the nature of CATSII, White Lite has developed a system which allows the user to quickly assess the state of health for any emergency lighting luminaire or exit sign. This is called a **SELF DIAGNOSTIC** emergency unit. All luminaires capable of being part of the Self Diagnostic System (**SDS**) will measure the status of the lamp and battery.

The luminaire has two LEDs and one Test Switch. LED (a) (Charge Indicator) is a static red and the other (b) is a bicolour LED that may either be flashing red or yellow. When the LED (a) is illuminated a static red, this will indicate that the mains is connected to the luminaire and that the charger is operating correctly. LED (b) indicates whether the luminaire has passed its last test, whether as a **Quick** test or an **Automatic** 90 minute test.

Each SDS unit is capable of two testing modes, Automatic and Manual, which are preset at the factory or on site. To enable the luminaire testing regime to be set or data to be retrieved from the units memory a special plug may be provided to allow a link from a laptop computer. The automatic tests can be preset to operate a Quick Test every 1-10 weeks (1-16minute) or a Full Test every 1-26 weeks (90minute). However, when the user requires for a quick analysis to be performed on the luminaire, each SDS has been fitted with a test switch which performs the Quick Test for the preset time limit. The LED(b) will then flash red or yellow when the unit fails or passes the test. When the LED flashes red it may indicate that the lamp, battery or both have failed to pass the minimum allowable thresholds. The fault priority would normally be that the lamp has failed first, then the battery.

As with the CATSII standard luminaire, SDS units still allow data cable to be connected to them at a later stage in the project. Also the SDS units are fully integrateable with existing CATSII installations.

When specifying SDS units please the following catalogue number suffix.

For example: Mustang Self Diagnostic System, 2 x 10W sustained nicad CATSII monitored exit sign is **MGC210S-SD** or 10W 6V non maintained nicad recessed halogen emergency Pathfinder is **PFC10F-SD**.

Part II

INSTALLATION INSTRUCTIONS

2.1 GENERAL

The White Lite CATS II System will monitor a complete emergency lighting system and will accept any emergency luminaire fitted either internally, externally or remotely with a CATS II circuit board.

The system requires an IBM style, 486 or above computer which is fitted either with an internal RS485 communication card or an external RS232 to RS485 adaptor. The computer must be on site as soon as possible, so as to allow the quick connection of the luminaires and easier diagnostic control over the new system.

2.2 INSTALLATION

It must be borne in mind that installing the communications cable is quite different to installing mains cable. The size is smaller and because of this it is more fragile in termination, and the installer must be on the watch for cable breaks not only in the line but at points of termination.

Cable Type: Shielded cable must be used at all times to limit the incidence of induction from other equipment. A braided or aluminium shield covering either each or both conductors is required. Single twisted pair is the minimum requirement as the twisted conductors help to balance out any induced signals. It is preferable to use multistrand conductors to limit the risk of breaks, 7/0.2mm is recommended. Good data transmission is essential and level 3 data cable or better must be used.

Recommendation: ***Shielded single twisted pair, 16/0.2mm multistrand, 415V rated, UL rating level 4 data cable. Similar to MM cables No.: B3102CS***

Cable Laying: **It is important to remember at all times that the communications cable must be kept segregated from any mains (low, high voltage) cables.** However, if the data cable is laid beside, tied to or in the same conduit as the mains cable, and the cable is not rated for high voltage, then there is a risk of induced voltages eg. spikes or other noise interfering with the microprocessors' operation. We recommend that a minimum of 300mm be maintained or if unable to comply with this limit contact our engineers for advice. AS3000 C1.1.4.9.3. requires a minimum of 50mm between low and extra low voltage cables.

Terminations: It is recommended that any terminal blocks or connectors used have wire protectors in order to prevent the wire being cut by screws.

2.3) WIRING THE EMERGENCY LUMINAIRE

(I) CATS II CONTROL BOARD FACTORY FITTED INSIDE THE LUMINAIRE

(a) **Connect mains to the terminals marked "earth", "neutral", "unswitched active" and "switched active".**

(b) Connect the communications cable to the polarised terminal block marked **Communications +** and **-**. The data cable used is standard twisted pair data cable with one pair used for + and -. **YOU MUST OBSERVE POLARITY WHEN CONNECTING THE CABLE.** Failure to do so will prevent the computer from interrogating the unit and an error message will appear on the computer status screen. The communications cable is looped from one fitting to the next as shown in the diagram over. **(Refer to Figure 1 for typical wiring of Cats control board to standard emergency units)**

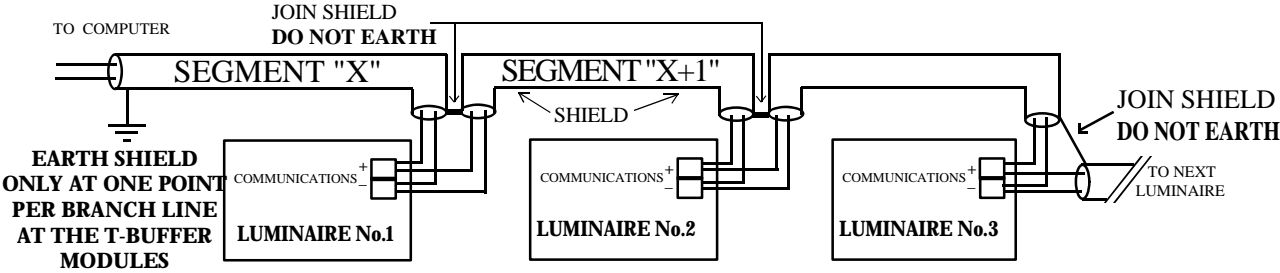

Figure 1: Typical branch line data cable & shield termination layout

(c) Please note that in order to have a continuous shield throughout the entire system it is necessary to join the drain wire at each unit and earthed at each T-buffer or the System Computer. This can be achieved with the use of BP connectors or terminal blocks

(d) As the fittings are connected to the communications cable an accurate record of their type and location MUST be kept. A location sheet is included (see page 17 or the example on page 9) for this purpose.

It is desirable to plan the complete installation with the luminaires added in numerical order, starting with the luminaire closest to the computer. It is a simple matter to re-number light fittings from the central computer once the installation is complete. However, a little care in the first place will save time at the commissioning stage of the installation.

Note: changing the external identification label on the luminaire is time consuming.

Because of the possible number of luminaires which may be connected across the communications line, an additional buffer is included in each 29th luminaire as numbered in the factory. For example if the factory units are numbered 1-29, 100-129, 200-229, etc. Then the buffers will be in the units numbered 100, 200, 300, etc.

If a unit is wired out of sequence within e.g. the group 100-129, there is no problem. However, if a unit from an earlier group is put into a later sequence e.g. 100, 101, 102, 20, 103..... etc., then the computer will not communicate with No.20 until it is re-numbered within the region of 100-129.

Changing numbers within, say 100-129, is readily done from the system computer. However, re-numbering a unit in the wrong group is to be avoided wherever possible.

It is recognised that it is almost inevitable that changes will be required either in placement, or in the number of luminaires required during installation, or after the system has been commissioned. Should more than this be required, a unit containing a buffer module should be installed. (See Figure 2)

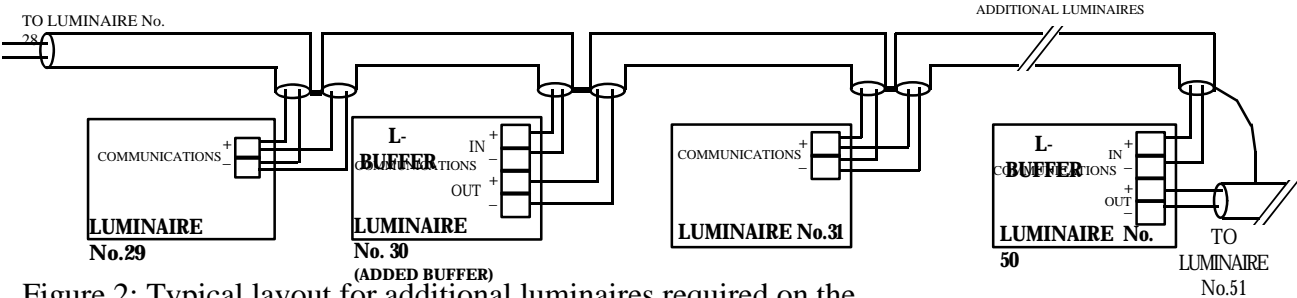

Figure 2: Typical layout for additional luminaires required on the branch line

The luminaires must be looped from one to the next as shown. Spurs should be avoided as this can interfere with communication with the computer.

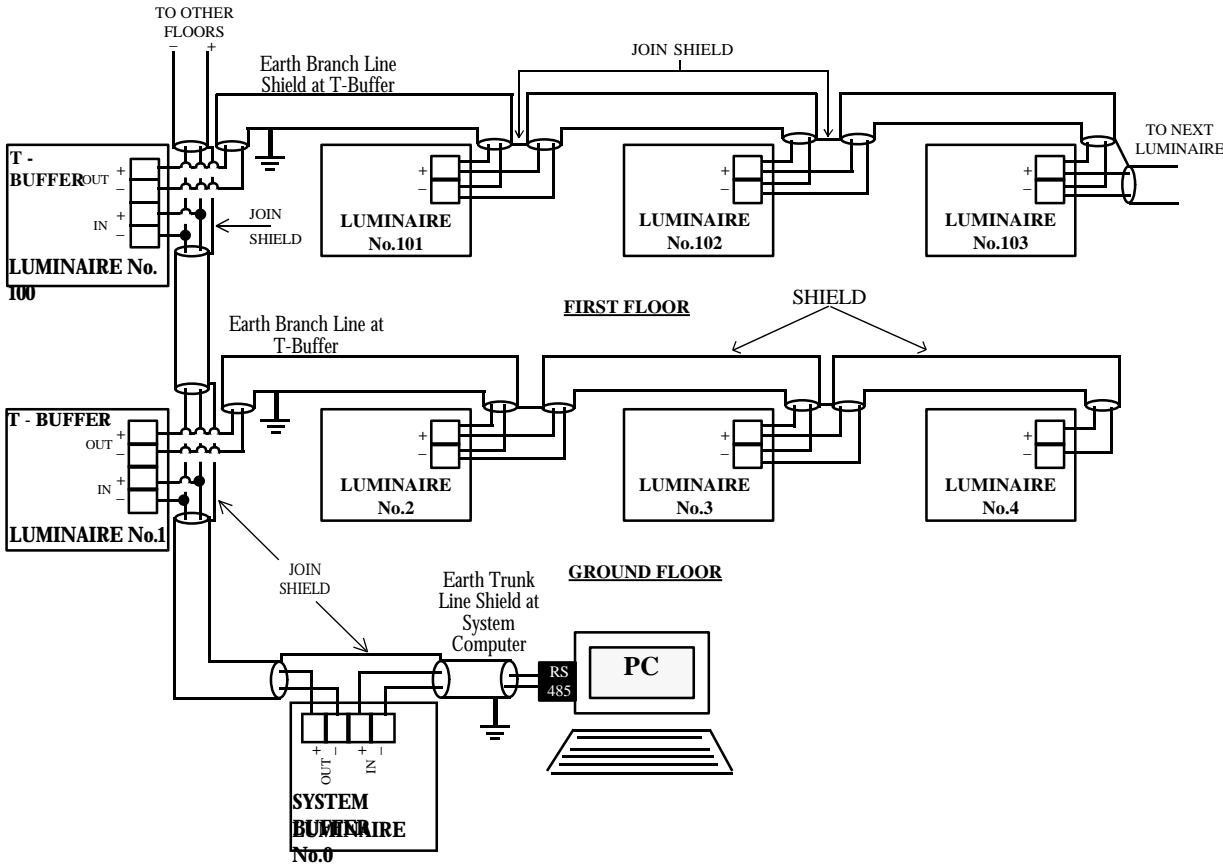

Figure 3: Typical Multi-level data cable layout

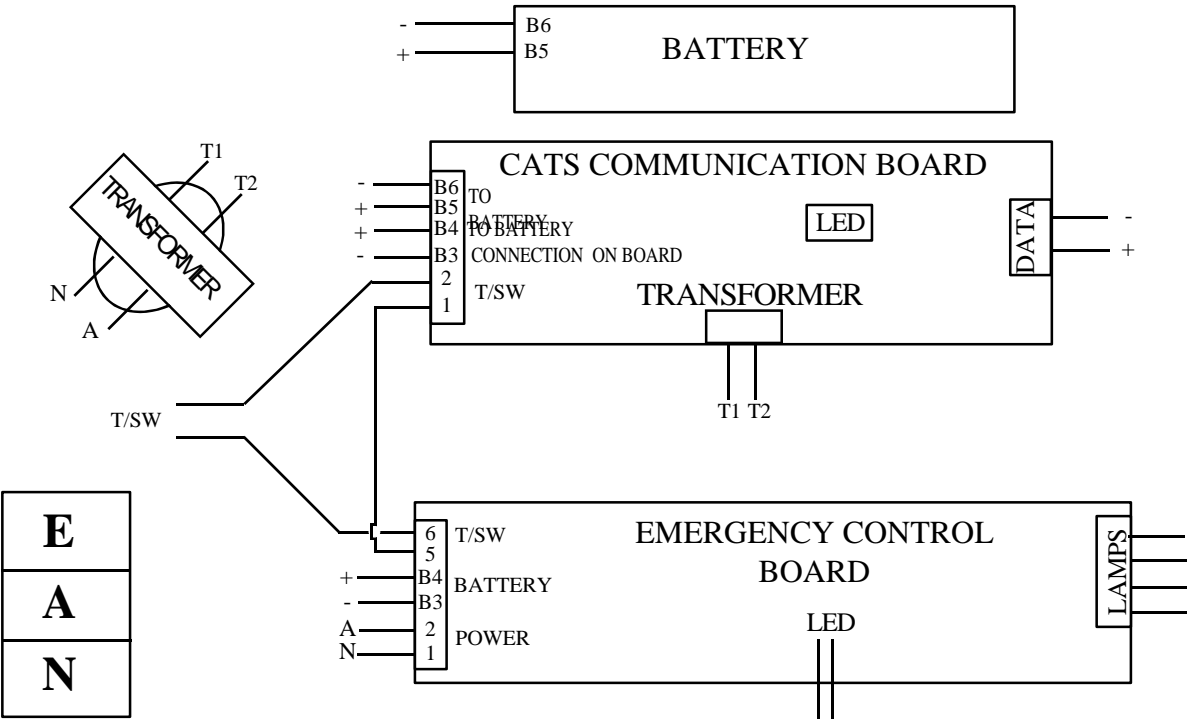

Figure 4: Typical wiring diagram for CATSII communication board to Exit or Emergency luminaires

(II) **CATS II CONTROL MODULE FITTED EXTERNALLY TO A WHITE LITE LUMINAIRE**
 The external circuit board is fitted in a box which is factory connected via a cable to the emergency luminaire. Mains is connected to the luminaire by wiring to the CATS II Control Board.

- (a) Remove the 4 screws holding the cover onto the CATS II Control Module. Connect "earth", "neutral" and "unswitched active".
- (b) Connect the communications cable to the polarised terminal block marked **Communications** + and - and loop to the next luminaire. Join the shields together.
- (c) Replace cover on the CATS II Control Board.

(For other details of numbering and fitting of buffers see section 2.3.I)

(III) **CATS II CONTROL BOARD FITTED EXTERNALLY TO ANY EXISTING SELF CONTAINED EMERGENCY LUMINAIRE**

To link the CATS II Control Board to the emergency luminaire the following leads must be broken and connected to the multicore cable coming from the CATS II Control Board:-

Battery Positive	Battery Negative
Test Switch	

The 3 core mains cable from the CATS II unit connects the following wires to the mains terminal in the luminaire.

Brown(Red)	Unswitched Active,
Blue (Black)	Neutral,
Green	Earth.

The LDR and should be installed directly below the emergency lamp and at a distance of approximately 25mm.

(The communications cable is connected as detailed in section 2.3.I)

2.4 System Status Screen

This screen is the System Status Screen which will illustrate to you the status of 800 to 1,300 emergency luminaires, depending on screen size.

The luminaires are numbered from left to right in five groups of 10, i.e. 0 - 9, 10 - 19, 20 - 29, etc. In each 100 luminaires there are two rows. The top row is numbered as indicated in the first row of the screen, e.g. 0 - 49, 100 - 149, 200 - 249, etc. The bottom row is numbered as indicated in the second row of the screen, e.g. 50 - 99, 150 - 199, 250 - 299, etc.

	0	10	20	30	40	49
	50	60	70	80	90	99
0	#####	#####	#####	#####	#####	#####
50	#####	#####	#####	#####	#####	#####
100	#####	#####	#####	#####	#####	#####
150	#####	#####	#####	#####	#####	#####

As the screen fills up the computer is communicating with each luminaire and checking for any faults which were detected during the last test. These are identified by a letter on the screen in the luminaire's numbered position. The fault key on the right of the screen indicates problems as detailed below:-

L Lamp - this indicates a lamp failure.

B Battery - this indicates a battery failure.

T Temperature - the temperature measured in the luminaire has exceeded the level allowed for reliable battery operation. (This facility is optional.)

! █ Multiple - more than one fault has been detected. You may choose to display the Test Report under the System window, or print the report.

C No reply - the luminaire is not communicating with the computer and it may indicate a faulty communications board, or a luminaire has been logged on when it does not exist.

S Set Up - this indicates corruption in the luminaire's memory and refers to the original reference voltages entered.

M Memory - indicates a faulty memory device which is not responding to the computer's instructions.

.. No fault - the luminaire is operating satisfactorily.

Not logged - luminaire has not been connected to the communications cable.

N New Unit - a luminaire has been connected to the communications cable but has not been logged into the Data Base.

While in the Status Screen you can go to any luminaire's TEST REPORT by pressing F10 and if you want to see the geographical location, press F2 which brings up the VIEW LUMINAIRE Setup details. To obtain a list of faulty luminaires you can print the screen or go to the SYSTEM menu to print, for example, a Test Report. An ideal representation of the Status screen is shown below. To enter the Main Menu SCREEN - press ESC.

```

00      10      20      30      40
50      60      70      80      90
100 .. ## .. ## .. ##### .. # .. ## .. ## .. ## .. ## .. ## .. ## .. ## .. ##
    ##### .. ## .. ## .. ## .. ## .. ## .. ## .. ## .. ## .. ## .. ## .. ##
200 .. ## .. ## .. ##### .. # .. ## .. ## .. ## .. ## .. ## .. ## .. ## .. ##
    ##### .. ## .. ## .. ## .. ## .. ## .. ## .. ## .. ## .. ## .. ## .. ##
300 .. ## .. ## .. ##### .. # .. ## .. ## .. ## .. ## .. ## .. ## .. ## .. ##
    ##### .. ## .. ## .. ## .. ## .. ## .. ## .. ## .. ## .. ## .. ## .. ##
400 .. ## .. ## .. ##### .. # .. ## .. ## .. ## .. ## .. ## .. ## .. ## .. ##
    ##### .. ## .. ## .. ## .. ## .. ## .. ## .. ## .. ## .. ## .. ## .. ##
500 .. ## .. ## .. ##### .. # .. ## .. ## .. ## .. ## .. ## .. ## .. ## .. ##
    ##### .. ## .. ## .. ## .. ## .. ## .. ## .. ## .. ## .. ## .. ## .. ##

```

PART III
TROUBLE SHOOTING GUIDE

3.1 PC SETUP

Your computer should have the following minimum requirements:

486SX CPU 4MB RAM 40MB HARD DISK 3.5 DISK DRIVE
2 Communication Ports Monitor Keyboard Mouse (optional) MS-DOS 6.22 Window 95/98

Also needed for the monitoring system is the **CATSII software** and the **RS485 converter**.
(Note that the computer should be set up in an area that is away from direct heat and any type of industrial machinery/electronic devices that may disrupt the computer operating properly.)

3.2 INSTALLING SOFTWARE

When installing the software onto the computer please note the version of the disk from WLI. The latest versions of the CATSII system include V1.03, V1.04 and V1.08 . The software is DOS based and therefore can be installed via Windows or through DOS.

The CATSII programme has a quick self-install facility built into the system. Your hard disk must have a minimum of 40MB (ROM) memory, more is advisable but not necessary. Insert the disk into the 3.5" disk drive and follow the instructions below for the operating system which is applicable for you.

MS-DOS (Version 6.x)

(New Installation)

(At the C:\> prompt) Type "a:"

(At the A:\> prompt) Type "INSTALL C:\CATS2N Y Y"

(This line will install the CATSII software into the CATSII folder on your hard disk)

(Updating Old Installations)

(At the C:\> prompt) Type "a:"

(At the A:\> prompt) Type "INSTALL C:\CATS2N N N"

(This line will install the CATSII programme into your hard drive, but will not overwrite any existing luminaire and unit identification files.)

Windows 95 and Windows 98

(In main Desktop)

Click on the "START" button (bottom left corner)

Goto the Programs Icon and ultimately the MS-DOS icon.

(Follow the above steps for MS-DOS. (Applicable for New and Updating installations)

3.3 SIGNAL (POLARITY) INDICATION DEVICE (SPID)

This device is simply for the purposes of testing the polarity of the data cable on the system. The device can be connected directly to the data cable and will indicate whether the data line has the correct polarity or not. The LED will illuminate if correct and will not illuminate if the polarity is wrong. Note that the LED does flash when the Status Screen is polling, therefore, in order to check if the polarity is correct wait until the Status Screen stops polling.

(Available from White Lite Industries upon request.)

3.4 RS-485 CONVERTER (INTERFACE)

You will have received an RS-485 converter with your goods or computer, if you have not received one please call White Lite Industries Customer Service. Simply the converter changes the data signal from the computer (RS-232) to RS-485 system. The CATSII system will not operate with any other type of converter.

The RS-485 converter plugs into either the COM 1 or COM 2 ports of your computer. The converter comes complete with power supply, Users manual and 9 pin (female) to 25 pin (male) cable. Please use the following settings CATSII system.

Set the switches on the converter to the following positions: SW1: DCE; SW2: T-RTS RxON, connect the power transformer to the coverter and plug the converter into the COM 2 port at the back of the computer. (Note: That if the COM port is physically changed, then the settings in the program also need to be changed.) The data cable wiring is setout in figure 5.

A special RS485 can be used for laptop computers. This uses the port as a source of power. The settings and wiring for this type of converter are different from the above converter. For the wiring please see below. The settings for the three switches are: SW1) DCE, SW2) SIM & SW3) T-RTS/R-ON. When these settings are used both LEDs on the converter should flash when in the CATSII software. The data cable wiring is setout in figure 5.

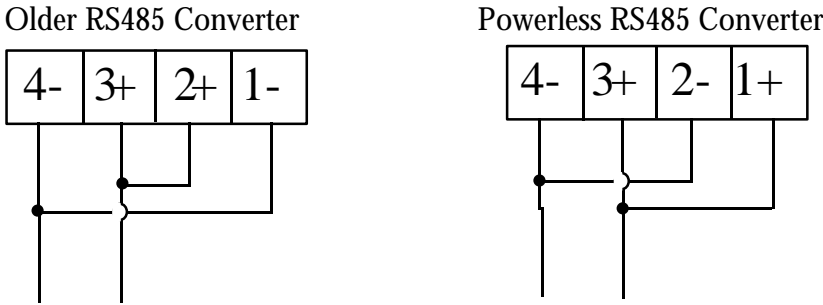

Figure 5: Typical data cable wiring for Powerless and Older RS485 converters

3.5 PASSWORD

Note that the CATSII software is your responsibility and has a security password function built into it. After you have installed the software enter the CATSII programme. Enter through the PASSWORD window, into the CATSII status screen. Press ESC twice to get to the CATSII desktop. Using the ALT key and Arrow keypad, go to the Options Menu. Once in the Options menu, move to the Change Password option. You will be asked to enter the old password (if none press Enter), type your new password and press Enter. (NOTE: This facility is CASE SENSITIVE, so if you enter your password in Upper Case(Eg: 'CATS'), the program will not recognise it in Lower Case (Eg: 'cats').

3.6 Fault Diagnosis

<u>Symptoms</u>	<u>Problem</u>	<u>Solution</u>
Red Flashing Bi-Colour LED: (Failed last Test)	Computer not connected System not communicating	Check Computer cables Check RS485 setup Check data cable to computer & luminaire
	Failed to pass Test - Lamp fault - Board fault	Battery fault -Change Battery Change Lamp
	Running Maintenance test	Change Control Board Will change when the test has passed
Red Solid Bi-Colour LED: (Failed last Test)	Normal operation mode Computer Status screen polling & Failed Last Test	

Yellow Flashing Bi-Colour LED: Normal operation mode
(Passed last Test) Running Maintenance test

Yellow Solid Bi-Colour LED: Computer Status screen
(Passed last Test) polling & Passed Test.

Red Charge LED On Luminaire is Operating

Red Charge LED Off Luminaire is faulty.

Luminaire not Illuminated Lamp faulty Check lamp

In CATSII Status Screen

After a test has been performed on the system, the Status Screen will indicate which fittings require attention through a letter classification system. The fault legend is described as follows:

(For colour monitors, the letters are colour coded; see below)

(Red Bold)

L	Lamp:	lamp fault
B	Battery	battery fault
T	Temperature the luminaire has	the temperature measured in exceeded the level allowed for safe operation (Optional)

(Red Shadow)

!

Multiple	two faults detected. To display the faults goto TEST REPORT (in SYSTEM Window) or print the report.
----------	--

(Yellow Bold)

C	No Communication	the luminaire is not communicating with the computer and it may indicate a faulty CATSII board or that a luminaire has been logged on when it does not exist.
----------	---------------------	---

(Purple Bold)

S	Setup	indicates that the luminaire's memory has been corrupted and recalls the original reference voltages entered.
----------	-------	--

(Orange Bold)

M	Memory	indicates a memory device fault, which is not responding to the computer's instructions.
----------	--------	--

(Blue Bold)

◆

No Fault	luminaire is operating correctly.
----------	-----------------------------------

(White Bold)

#	Not Logged	luminaire has not been connected to the data/communications cable.
----------	------------	---

(Black Bold)

N

New Unit

new luminaire connected to the data cable but has not been logged into the database.

Trouble-Shooting

This section covers possible problems that have occurred in the past. Three levels have been identified; Level 1 (No communication: Please note that most communication errors can be solved by checking the most common places first), Level 2 (Some Communication: If you find any problems which can not be solved by this section, please call your local White Lite Industries Agent, Distributor or the Head Office) and Level 3 (Individual Luminaire fault: Call a White Lite Industries representative with regard to replacement/buying of spare parts.) Examples of possible communication error or fault scenarios has been included in the section.

No communications (Level 1)

Check the data cable for breaks in the line or interference to the cable.

Check that the connection of the cable to the luminaires and RS485 is as recommended.

Check that the cable is properly earthed and shielded.

There several possibilities why the luminaires are not communicating to the computer system.

- The computer is not connected to the data cable
- The luminaire is not logged with the CATSII system
- The luminaire has a faulty CATSII module board.

(Note: CATSII is a POLARITY sensitive system, if the cable polarity is reversed the system will not work. Use a Signal Indication Device (SPID) to check the line.)

- The RS485 is not correctly connected to the data cable or the computer.
- The data line is being interrupted by an outside interference, radio frequencies, microwaves and mains power lines will affect the data cable significantly.

Some Communication (Level 2)

Check that the buffers are installed correctly or that the line has the required amount of buffers installed for the CATSII version.

(NB: The current version for CATSII has been restricted to 25-32 luminaires per line before a buffer is required, however, future versions will have the capacity for upto 100 luminaires per buffer; available upon request at additional cost per module)

Check that there is mains power to the buffer module.

Check the buffer range number has been correctly set to factory settings. (see System Installation section)

{Default Setting = 99. Do not change this number unless advised to do so by WLI}

Individual Luminaire Fault (Level 3)

Check all connections to the board and CATSII board.

Check with the computer when diagnosing the fault. When the status screen shows an L or B, change the lamp or battery in the luminaires identified.

Check the charge rate inverter to the battery, if it is below the nominal voltage (seen in the Test Report) change the inverter or control board.

Check the setup of the luminaire types. If the minimum battery volts are set too high then the test will show a fault. This will also occur when the maximum voltage drop is set too low. To view these settings go to the Logged Luminaire Test (LLT) report.

Scenarios.

Eg 1:

Problem: "Daisy-Chain data cable line in a shopping centre complex has communication errors on the Status Screen".

Solution: Checking all data cable connections to the luminaires, make sure that the computer and RS485 is correctly setup and that the line polarity is correct {using a 'SPID'}.

Check that the cable has no breaks along the line and that the buffers are wired correctly.

Check that the L-Buffers are properly earthed and installed. Check that there is no more than 25 luminaires per buffer. For a system with 100 luminaires on the line there should be a minimum of 4 buffers.

Eg 2:

Problem: "Multi-Storey (6 floors) Carpark using a T-Branch setup, showing communication for first three floors but no communication on the remaining floors. Test completed and shows lamp and battery faults on the first and second floors".

Solution: Identify the faulty fittings from the computer and replace faulty parts as per the database in the computer.

Check all connections to all CATSII fittings (on the floors above three) for mains and data cable. Also check that there are no cable breaks on the line. Check that the T-Buffers are properly earthed and installed.

Check that the T-Buffer on the 4th Floor has mains power running from it, output voltage from the mains transformer should be 9.5-13V on the low voltage side. (red wires leading to the board) Check in the unit setup in the Database menu, that the Buffer Range number is the last allocated number before the next buffer (L or T). (eg: 3rd floor T-Buffer range number set to 399, 4th floor T-Buffer identification number is 400)

Eg 3:

Problem: The computer Status screen shows intermittent 'C' symbols across the entire complex. Hospital and Medical Centre complex. The 'C' symbols disappear and reappear with out warning.

Solution: Check that the data cable is the required distance (300mm) away from the mains power cabling as per Australian Wiring standards. Check that the cable is not next to sort of electrical motor, eg: an elevator motor or a generator. Check that the cable is not near any sort of MICROWAVE or X-RAY emitting devices, commonly located in medical facilities. This problem often signifies some sort of interference or noise on the data cable, and as a result will inhibit the capacity of the data cable to carry data to and from the computer, therefore showing a communication error.

There many different combinations of errors that could potentially occur in a system in Theory. No system is 'Fool Proof'. However, White Lite Industries or a representative is always a phone call away, if the problem goes beyond the levels described above.

Buffer Set-Ups

The buffer module should be pre-set by White Lite Industries technicians. However, the wiring for installing the buffers is very important and if not done correctly will cause communication faults on the line. White Lite defines two types of buffer modules for the CATSII system. Each module perform in a similar way, however, they are used differently.

Tree Buffers (T-Buffer)

Commonly used on "Multi-drop cabling site layouts. Eg: Apartment buildings, Multi-storey carparks, etc. The wiring must have a Trunk data line and the corresponding Branch data line, to be connected to the buffer. See Figure 1.

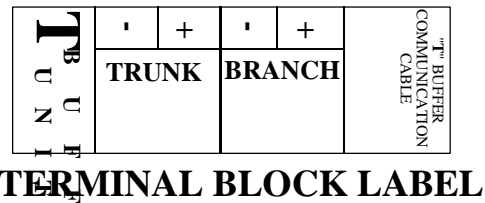
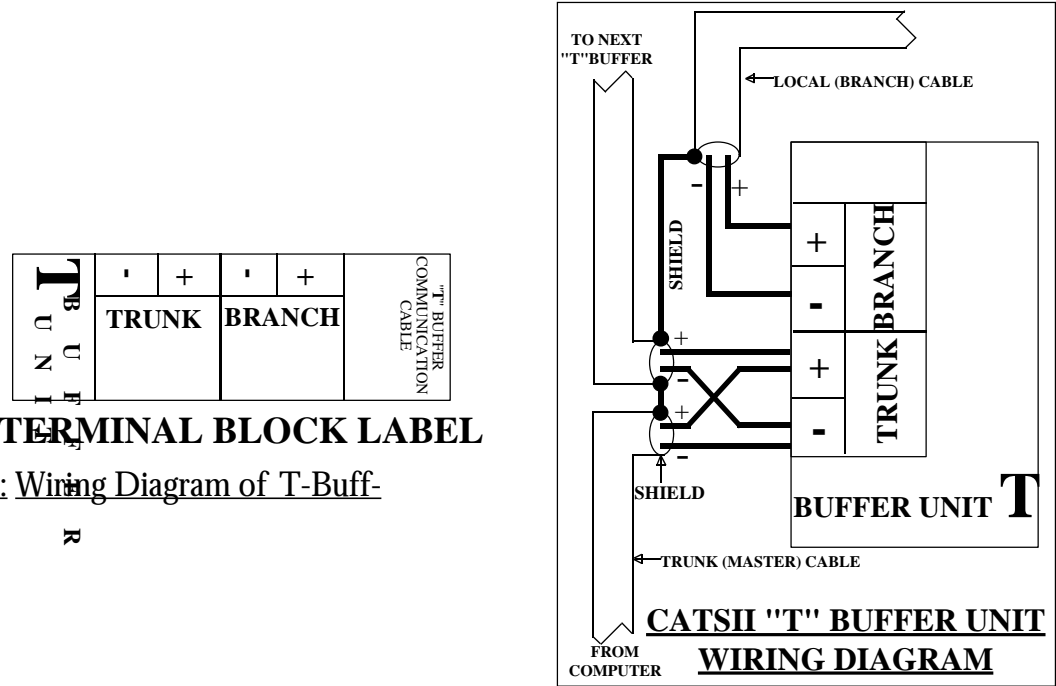

Figure 1: Wiring Diagram of T-Buffer

Line/Branch Buffers (L-Buffer)

Commonly used with "daisy-chain" layouts or adjacent to the T-Buffers. Eg: Each floor/building of an apartment or single building layout. WLI recommends that on the data line there are 1 buffer mdules per 25 luminaires used. A scematic of how the L-Buffer should be wired into the data cable has been shown in Figure 1.

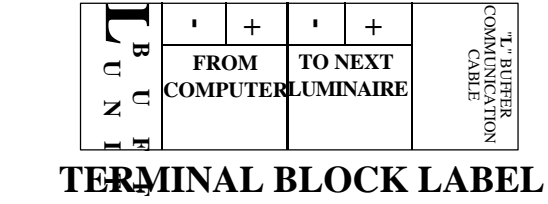
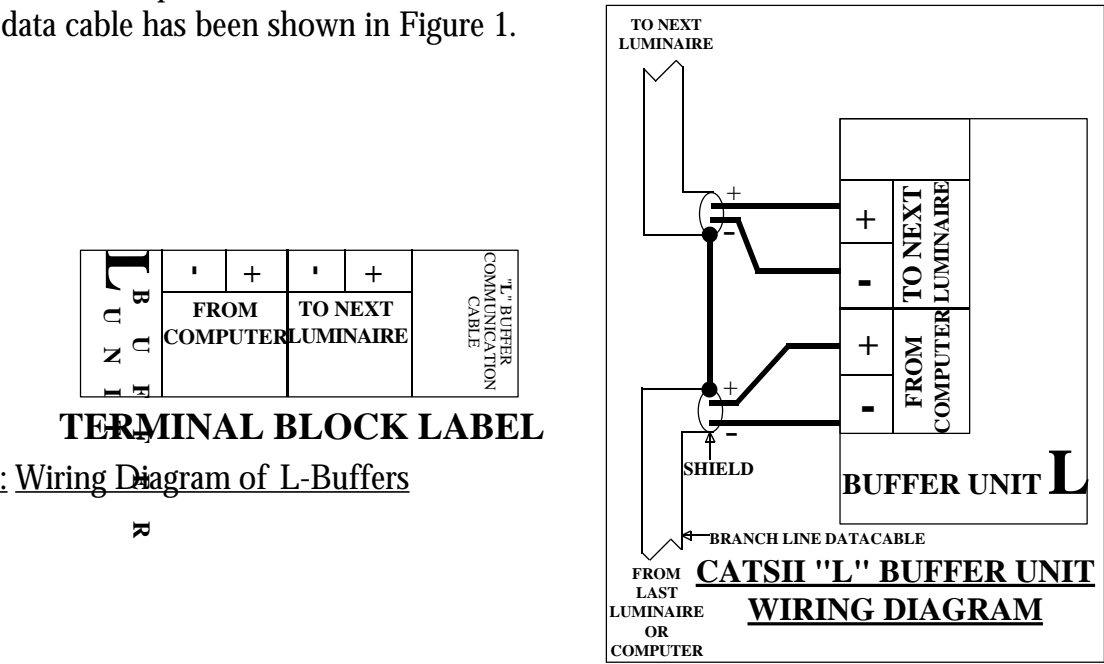
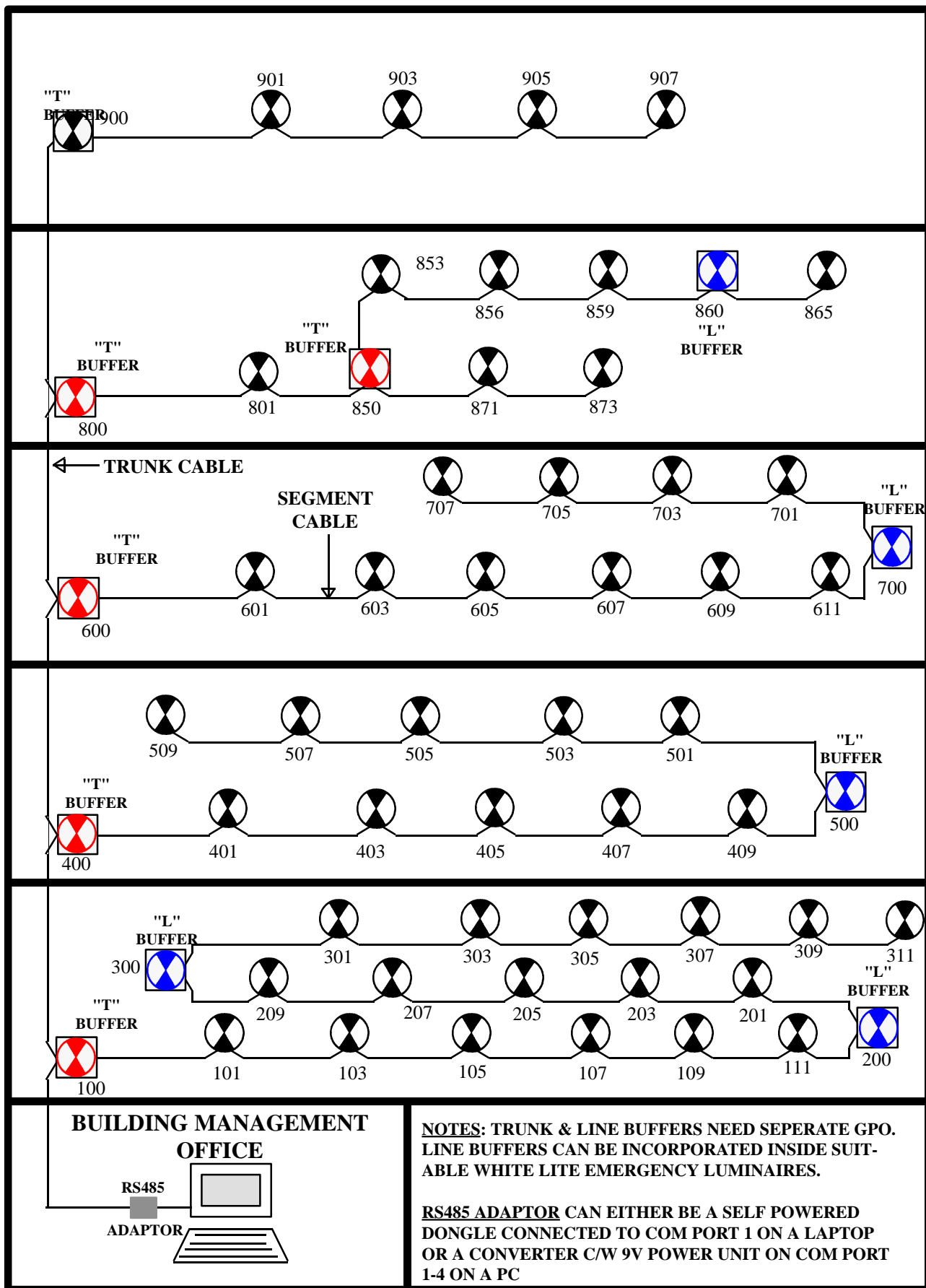

Figure 2: Wiring Diagram of L-Buffer





 T-BUFFER OR L-BUFFER  L' BUFFER

FIG. 5

 EMERGENCY LUMINAIRE

EXAMPLE OF TRUNK & SEGMENT COMMUNICATION CABLE CIRCUITS IN A MULTI-STORY BUILDING USING THE CATS II EMERGENCY LIGHTING SYSTEM

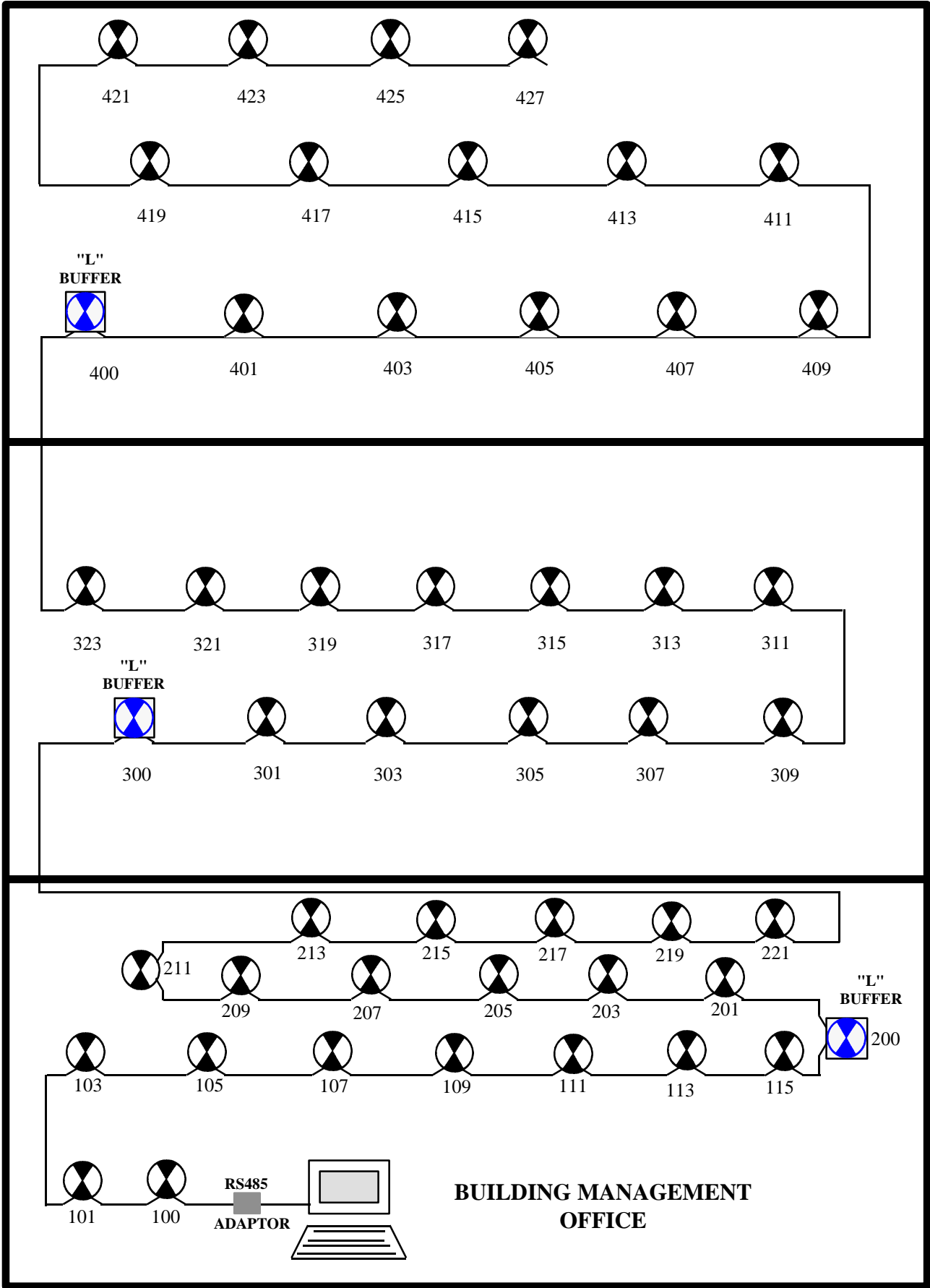

 BUFFERS "L"

FIG. 6

 EMERGENCY LUMINAIRE

EXAMPLE OF ALTERNATIVE COMMUNICATION CABLE CIRCUITS

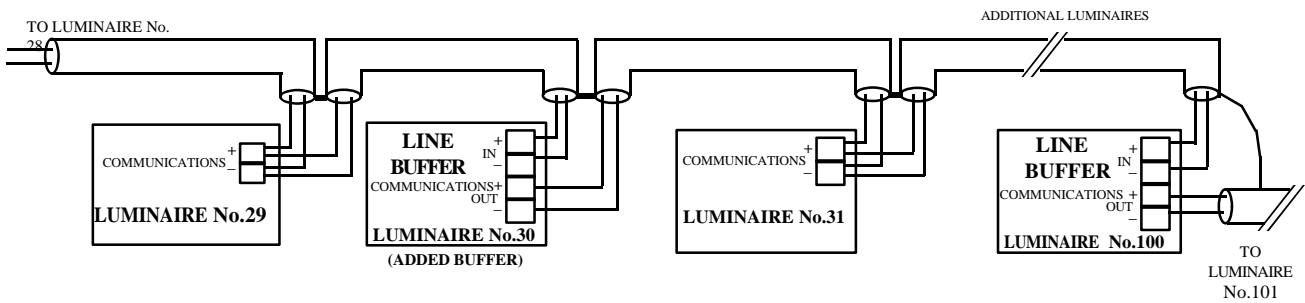

Figure 3: Schematic of a typical data line with L-Buffers and luminaires.

Note that the buffer range number, in buffer module unit setup window, must be set to the last allocated Identification number before the next buffer. The Buffer range will set the parameters for the buffer signal strength. Therefore, the set number will only cover applicable buffer and all the luminaires upto and including the luminaire's identified by the CATSII number. For example:

Buffer ID no. : 10. Buffer Range = 85.

The buffer will scan every luminaire ID no. from 10 until 85, only. Then the next Buffer ID no. 86 will take over the scanning of the line. In order to change the buffer range value please refer to Modifying Unit Setup.

Renumbering Existing Units

This is a simple procedure, the software has been designed to be relatively user friendly in a MS-DOS environment. Follow the instructions below for quick renumbering. Note you can renumber units in any part of the CATSII desktop, and that in order to for this function to work the system must have blue diamonds on the status screen.

Type CTRL + F11

Type the Unit Identification Number to be changed

Type the required ID number.

The program will update the luminaire and verify the procedure.

Short Cut Keys / Commands

- ESC Will EXIT out of all screen back to the previous screen or menu.
- F1 Help screen
- F9 Status Screen
- F10 Goto Test Report

CTRL + F11 Change Unit Number. (See System Installation)

CTRL + F12 Change Baud rate of Luminaire. (See Communication Menu)

Status Screen:

- HOME Go to Luminaire Identification No. : 0
- END Go to Luminaire Identification No. : 16385
- ENTER Re-display current screen
- F2 View Luminaire setup report. (shows geographical location)
- CTRL+ENTER Start Status Screen at a specific range of Luminaires.

In TEST mode:

- ALT+F6 Buffer location and buffer version status.
- ALT+F3 Test procedure for data communication cable. (see Trouble-Shooting)

Changing fitting types

It may be necessary to add, delete or modify a unit or the specific type of luminaire in some situations. For example: replacing a PFC10 (recessed) to a PFSQC10 (surface mounted). Unless the database is updated, the system will not recognise any new luminaire added to the project. In this situation the luminaire type and the new unit(s) will need to be added to the database. If you run into any problems please call White Lite Industries immediately.

In the main CATSII window. Goto System menu, Database menu and type your password (if required).

Unit Setup

Adding New Units

Have the New Unit CATSII Identification number handy. (This number identifies the physical location of each luminaire for the computer. Therefore, if the luminaire is located between two fittings in an area, the new units ID number should correspond with that sequence, Eg: Between units 510 and 520, New unit : 515. For units being added at the end of the system the computer will allocate a number or will let you type your chosen number in. Check that the Buffer range number is set to the specified number of luminaire or the result will be a communication failure, after adding the new unit.)

(In Database)	Select New Unit
<i>(In Luminaire Setup Entry)</i>	Type in required Number
	Hold down CTRL + -
<i>(List of existing luminaire types)</i>	Select the required Type
	(If the type required is not there, see Adding New Luminaire Type)
	Type in Location, Floor and Building Side.
	Tab through setup options to the end of the window. Do not change these settings.
	Esc out of the menu windows. Type F9 (Status Screen)

Deleting Existing Units

(In Database)	Select Delete Unit
	Type in required Number
	Type Enter
	ESC out of Menu windows Type F9

Modifying Existing Units

(In Database)	Select Modify Unit	Type in required Number
<i>(You need only modify the Type of Luminaire and Location of the Unit)</i>		
	Tab down to the end	Type Y to Save
	ESC out of Menu windows	
	Type F9	
(Changing Buffer range value)	Select Modify Unit	
	Type in required Number	
	When the cursor is flashing at "Building"	
	Press CTRL + INS.	Then UP Arrow
	Change Buffer value to required number	
	Tab down to the end	Type Y to Save
	ESC out of Menu windows	
	Type F9	

Luminaire Type Setup

The luminaires should already be in the existing database, before you receive the first delivery of luminaires. However, when adding a new luminaire type follow the next set of instructions. Before proceeding with this setup, please call the White Lite customer assistance help line. (ph: 02 9457 8877)

Adding New Luminaire Types

(In Database) Select New Type

Type in White Lite Industries Product code

(Eg: 1x10W Mustang exit sign; MGC110M)

Type in the settings given to you from White Lite Industries assistance for the next section.

When you type in all the settings, the computer will automatically update the database.

Now follow the above instructions (Adding New Unit) and the software will recognise the luminaire.

Type F9

Modifying or Deleting Luminaire Types

There should be no need for you to modify or delete a luminaire type from the database. If you require to do so, please call White Lite Industries customer assistance for help.

Viewing Luminaire Types

(In Database) Select New Type

Type in White Lite Industries Product code.

The luminaire will be shown as per factory installation.

(When finished) Type Esc, to exit from the viewing window.

Type F9.

Logging on New Units.

The result we are trying to achieve is the blue diamond status for the luminaire. When there are black "N" symbols on the Status screen, database for the job or site luminaires needs to be installed. The database is available from White Lite Industries. Please follow the instructions below.

[Ring White Lite Industries help line on (02) 9457 8877 and speak to one of the CATSII technicians if you run into any problems]

Step 1: Check that the computer was pre-set by WLI for your site.

If not, ring WLI and ask for the relevant Data diskette.

Insert the disk into the 3.5" disk drive. Copy the relevant luminaire and unit data files to the relevant CATSII folder, in the computer.

(See below)

At C:\> prompt

Insert Disk

Type A:

At A:\> prompt

Type XCOPY A:\LUM.ID1 C:\FOLDER NAME\

Type Y to overwrite the file.

Type XCOPY A:\LUM.ID2 C:\FOLDER NAME\

Type Y to overwrite the file.

Type XCOPY A:\LUM.ID3 C:\FOLDER NAME\

Type Y to overwrite the file.

Type Y to overwrite the file.
Type XCOPY A:\LUM.ID4 C:\FOLDER NAME\
Type Y to overwrite the file.
Type XCOPY A:\LUM.DAT C:\FOLDER NAME\
Type Y to overwrite the file.
Type XCOPY A:\UNIT.ID1 C:\FOLDER NAME\
Type Y to overwrite the file.
Type XCOPY A:\UNIT.ID2 C:\FOLDER NAME\
Type Y to overwrite the file.
Type XCOPY A:\UNIT.ID3 C:\FOLDER NAME\
Type Y to overwrite the file.
Type XCOPY A:\UNIT.ID4 C:\FOLDER NAME\
Type Y to overwrite the file.
Type XCOPY A:\UNIT.DAT C:\FOLDER NAME\
Type Y to overwrite the file.
Type C:\>
Enter CATSII

This procedure should have successfully transferred the relevant files to the computer. Again if there are any problems please give White Lite Industries a call on the supplied numbers. By installing these files the computer will be able to recognise the luminaires tested by the WLI factory technicians. For any luminaires being added to the system after the bulk of purchase orders, please go to Step 2.

Step 2: Follow the instructions given in Changing New Units - Adding New Units.

CATSII System Reports

The CATSII software is capable of producing two report types: Logged (Saved) Luminaire Test (LLT) Report and Status Fault Report. Both can be printed out, however, only the LLT Report can be seen on the screen.

Logged Luminaire Test Report

To VIEW

Go to System menu

Select Test Report (F10)

Select View

Type required ID No.

Type required Test No.

To PRINT

Go to System menu

Select Test Report (F10)

Select Print

[For all luminaires]

Select All

[For a range of Luminaire]

Select Group

Type in first ID No.

Type in last ID No.

[For a specific Unit]

Select Unit

Type in first ID No.

(Note: The program will print out what has been requested automatically)

This test report will identify the Unit ID no., Test No. Test date, that the luminaire is operating and what type test is being performed on the fitting at that moment.

The results are divided into two parts, the left column consisting of factory test data, the right made up of data from the most recently performed test. The test data in the right column must be lesser or greater than the value in the corresponding data set in the left column to pass the test.

For example:

<u>Factory Default</u>	<u>Current Test Data</u>	<u>Result</u>
Minimum Battery Volts: 5.0	Measured Battery Volts: 6.4	Pass
Maximum Voltage Drop: 2.5	Measured Voltage Drop: 0.2	Pass

{Voltage Drop refers to the amount of volts lost between the start of battery discharge and the end of discharge}

Status (System) Fault Report

Go to Status Menu

Select Print

Type first luminaire ID number.

Type last or a specified luminaire ID number.

(The report will print automatically without any prompting)

This report is a quick glance at all the luminaire current status, giving the operator information on the individual units, including location, type, fault analysis. The report also gives the total number of faults for the system, dividing them into each test type.

Test Configuration

The CATSII software is capable of running five types of test on the system at any one time. These tests include Lamp Tests, Battery Voltage, CATSII configuration, Communication and Unit Temperature (Optional test). The test can be setup through two methods. Either use the factory defaults set by WLI or configure the tests to your requirements. If this is your option please follow the below instructions. Before, attempting to change the default settings please call White Lite Industries help line.

(It must be noted that test configuration must be based upon AS/NZ 2293.1, which states that a minimum of two maintenance test are run each year, 6 monthly)

Go to System Menu

Select Database

Enter Password (If applicable)

Select Modify Type (Under Luminaire Set-up)

Select Luminaire Type

TAB to Auto Full Test Enable

Type Y/N

TAB to Auto Quick Test Enable

Type Y/N

These test functions will run the 'Full Test' either/or the 'Quick Test' at the set frequency. For example: 'Full Test' Frequency(weeks): 26 (one test every 26 weeks) If the required frequency is greater than every 26 weeks then change the default number. Use the same procedure for the 'Quick Test' Frequency.

If it is required to change the time at which the 'Quick Test' activates then TAB to Test Time (0-23 hrs) and enter the required hour of the test eg: enter 2; the test will start at 2am.

{Please note that the system will allow the operator to configure tests to be run on a group of units or lumianires types or individual units. In most circumstances the default settings should be sufficient, however, the option is there if required.}

Saving Test Reports

The CATSII software is capable of saving upto 4 test reports. To save a test report see below.

Go to System menu

(for all luminaires)

Select Test Report (F10)

Select LOG

Select Create

Select ALL

(This will save all of the test reports done (past & present) for each luminaire in the system. The screen will flash each time the test report is saved.)

(for individual units & test reports)

Select Unit

Type Unit ID No.

Type required Test Report No.

(for a specific group of luminaires)

Select Group

Select Unit Range

Type first Unit ID No. in group.

Type last Unit ID No. in group.

Type first Test Report No.

Type last Test Report No.

{Note: The format used for saved test data is filename.LOG. It will be named using the date that the test reports were saved on. Eg: date.LOG or 04-21-98.log}

EXPORT & IMPORT LOG REPORTS

Export Log:

This selection will prompt you for an existing log file to export. You can type the name of the log file or press enter to see a directory list of log files on your system.

The exported file is a COMMA(,) SEPERATED VALUE (CSV) file, which is reconised by most spreadsheet programs. Eg: Microsoft EXCEL or Lotus 123. The file name generated will have the same name as the original log file, except with a ".CSV" extension. The file will be stored in the same directory as the original file.

Export Fault Log:

This selection will prompt you for an existing log file to export. You can type the name of the log file or press enter to see a directory list of log files on your system. The program will then search through the selected log file for units with failed test report or fault with the lamp or battery.

The file name generated will have the same name as the original log file, except with a ".CSV" extension. The file will be stored in the same directory as the original file.

Export Unit:

This will export the Luminaire database, which contains all the units in the currently selected building.

The exported file is a "CSV" file. The file name will be "UNIT.CSV" which will be stored in the same directory used to store the unit database for the currently selected building.

Export Type:

This will export the Luminaire Type database, which contains all the luminaire types in the system.

The exported file is a "CSV" file. The file name will be "LUM.CSV", which will be stored in the same directory as the CATS program.

Import Unit:

This selection will prompt you for a "CSV" file to import each units configuration data into the luminaire database for the currently selected building. You can type the name of the "CSV" file or press enter to see the directory list of CSV files on your sytem.

The CSV file must have the correct data format in each record in order for it to be imported. If there is an error in the format the rest of the import will be terminated with a brief error message indicating the error. The format of the data can be found by examining an exported CSV file using the Export Unit funtion. The exported file can be imported into most spreadsheet programs, such as Microsoft EXCEL, for viewing or editing and can be re-imported back into CATS if ther file is aved back in the CSV format. Each line in the CSV file is an individual record for each Luminaire. During import, any existing Luminaire in the database will be updated if containd in the import file and any new luminaires in the import file will be added to the database.

No luminaires will be deleted by the import function. If the luminaire belongs to a type not existing in the Luminaire Type database, then that type will be created in the Luminaire Type Database, based on the settings of the first luminaire of that type imported. Note however, that the text descriptions associated with the luminaire type, such as type, rating and number will need to be manually edited as they will need to be set with the contents of the previous luminaire type accessed in the database.

Import Type

This selection will prompt you for a "CSV" file to import Luminaire Type configuration data into the Luminaire Type database. You can type the name of the "CSV" file or press enter to see the directory list of CSV files on your sytem.

The CSV file must have the correct data format in each record in order for it to be imported. If there is an error in the format the rest of the import will be terminated with a brief error message indicating the error. The format of the data can be found by examining an exported CSV file using the Export Type funtion. The exported file can be imported into most spreadsheet programs, such as Microsoft EXCEL, for viewing or editing and can be re-imported back into CATS if ther file is aved back in the CSV format.

Each line in the CSV file is an individual record for each Luminaire Type. During import, any existing Luminaire Type in the database will be updated if containd in the import file and any new luminaire types in the import file will be added to the Luminaire Type database. **No luminaires Types will be deleted by the import function.** If the luminaire type belongs to a type not existing in the Luminaire Type database, then that type will be created in the Luminaire Type Database, based on the settings of the first luminaire type imported. Note however, that the text descriptions associated with the luminaire type, such as 'type, rating and number' will need to be manually edited as they will need to be set with the contents of the previous luminaire type accessed in the database.

Field Name Abbreviations:

In order to make the length of the field header record reasonable, many of the configuration field names have been abbreviated as follows:

<i>FTE</i>	-	Auto Full Test Enable (Y/N)
<i>AQT</i>	-	Auto Quick Test Enable (Y/N)
<i>MLT</i>	-	Mains Lamp Test Enable (Y/N)
<i>ELT</i>	-	Emergency Lamp Test Enable (Y/N)
<i>SBT</i>	-	Static Battery Test Enable (Y/N)
<i>DBT</i>	-	Dynamic Battery Test Enable (Y/N)
<i>TTE</i>	-	Temprature Test Enable (Y/N)

- LTM** - Lamp Test Method, Lux or Current (L/C)
- FTF** - Full Test Frequency (1 to 256) weeks
- QTF** - Quick Test Frequency (1 to 15) weeks
- QTP** - Quick Test Period (1 to 16) minutes
- TD** - Test Day (0 to 6) days, 0 = Monday
- TT** - Test Time (0 to 23) hours

- LSV** - Minimum Battery Voltage (0.00 to 14.63) Volts
- LDV** - Maximum Drop in Voltage (0.00 to 14.63) Volts
- ELC** - Emergency Lamp Minimum Lux/Current (0.00 to 2.55) Units/Amps
- MLC** - Mains Lamp Minimum Lux/Current (0.00 to 2.55) Units/Amps
- MTP** - Maximum Operating Temperature (0.0 to 127.5) °Celsius

- MLSV** - Measured Minimum Battery Voltage
- MLDV** - Measured Maximum Drop in Voltage
- MELC** - Measured Emergency Lamp Minimum Lux/Current
- MMLC** - Measured Mains Lamp Minimum Lux/Current
- MMTP** - Measured Maximum Operating Temperature

Please see below for an example of the export output page

SBT	DBT	MLT	ELT	LTM	TTE	LSV	MLS	LDV	MLDV	MLC	MMLC	ELC	MELC	MTP	MMTP	Test Duration
Y	Y	N	Y	L	N	4.1	6.1	1.4	1	1	0.07	1	2.25	70	0	> 210
Y	Y	N	Y	L	N	4.1	6	1.4	0.9	1	0.08	1	2.27	70	0	> 210

Above data represents standard values from an exported test report