

The successful MUSTANG exit sign range has been reborn with LED-TEC...!

1990: The original MUSTANG featured the latest in technology design in using the highly efficient Sub C cells and increasing the battery voltage to 6V DC, a move which saved lots of mains power and internal heat. This technology was called the EXIT-TEC inverter design which also was the first to introduce the "permanently maintained" mode whereby the sign was illuminated 24 hours a day. These advances were copied by others, who still use these designs today.

2003: The MUSTANG was then superseded by the new EXODUS exit sign which was driven by the SWITCH-TEC inverter system which allows the sign to be converted from maintained to non maintained with the flick of an internal switch. This is a boon to installers who have to use either and want to carry one type in their van.

2006: Today's MUSTANG again breaks new ground by using the best features of the previous systems and introduces "LED-TEC", where the light source is 32 white LEDs giving excellent diffusion and with a design life of 10 years mean time to failure.

Look at these features:

- Long life light source
- Low current consumption 0.03A at 240V
- Low power 2W LIGHT SOURCE
- Total power consumption 7.5W at 240V AC
- High temperature nicad battery
- Permanently maintained
- Maintained to non maintained internal switch
- Complete geartray + diffuser retrofits existing "shoebox" exits
- Approved to AS2293.1&3. 1995
- Multi conduit entry base with plug in gear tray



**CATALOGUE NO. MU24M**

<b>SUPPLY</b>	240V +-5% 50hz AC, 0.03A
<b>POWER CONSUMPTION</b>	Total Power Consumption 7.5W at 240V AC
<b>LAMP</b>	32 White LED panel 2W
<b>BODY</b>	ABS
<b>DIFFUSER</b>	Acrylic silk screened or vinyl decals
<b>MOUNTING OPTIONS</b>	Wall and Ceiling
<b>STANDARD</b>	LED charge indicator and test switch
<b>MONITORING OPTIONS</b>	BULLDOG Powerline & Dataline, CATS II Dataline
<b>DIMENSIONS</b>	24M viewing distance: Wall H 160mm x L 390mm x D120mm Ceiling H 225mm x L 390mm x D160mm
<b>COMPLIANCE</b>	AS/NZS 2293.1 1995, AS 2293.1&.3 2005 BCA 1990 - 2006, S.I.S.I.R. CP19
<b>CERTIFICATION</b>	Certification Nos: Photometric LSA 8892 (single sided), LSA9076C (double sided), Thermal LSA0432102T
<b>GUARANTEE</b>	12 Months against faulty parts or workmanship



Mustang Exit Wall Mounted (Single Sided)  
FRONT VIEW

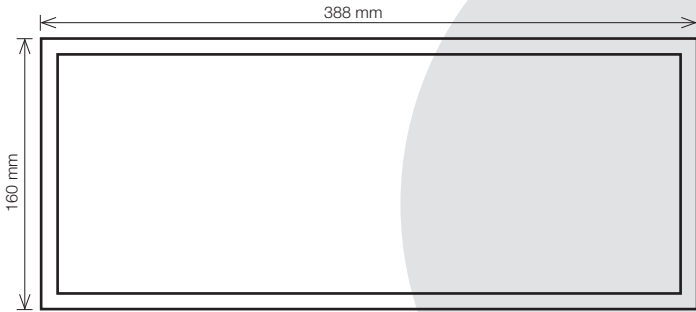

Mustang Exit Ceiling Mounted (Double Sided)  
FRONT VIEW

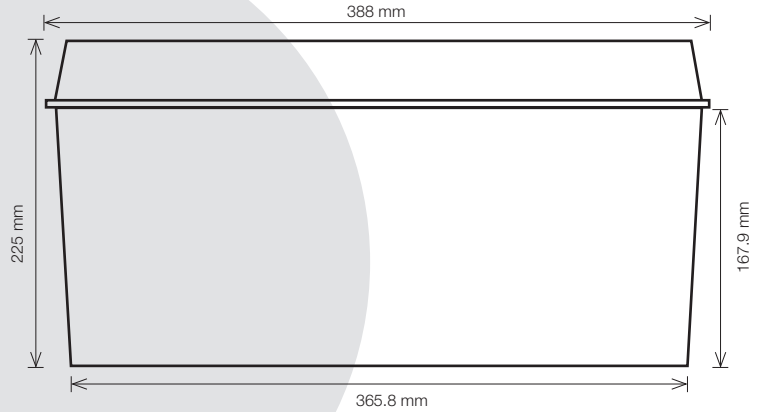

Mustang Exit Wall Mounted (Single Sided)  
SIDE VIEW

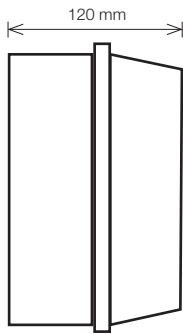

Mustang Exit Ceiling Mounted (Double Sided)  
SIDE VIEW

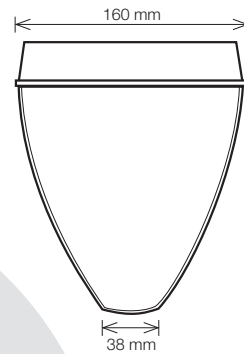

Mustang Exit LED -TEC

